

LPW2 / LPW3 / LPW4



**Water-cooled
Direct Injection
Diesel Engines**

Technical Data Sheet



Standard Equipment

- Flywheel drilled for automotive clutch
- Flywheel housing with SAE5 flange
- Fuel filter with water trap
- Fuel lift pump
- Governor - fixed or variable speed
- Grey paint finish
- Inlet & exhaust manifolds
- Inlet manifold heater plug
- Lubricating oil filter
- Operator's handbook
- Self-vent fuel system
- Tapping for speed detection
- Water circulation pump & thermostat

Accessories

- Air cleaner - medium or heavy duty
- Alternative speed and stop/run control devices
- Engine protection switches & solenoids
- Exhaust flanges or silencers
- Fan drive guards
- Flywheel end drives, shaft extensions and half couplings
- Gauges - supplied loose
- Gear end drives
- Hydraulic pump drives - gear end and/or flywheel end
- Radiators - mounted or loose, with or without cooling fans
- Inlet and outlet cooling air ducting
- Start panels - mounted or loose
- 12 volt starter motor & 45 amp battery charging alternator
- 12 litre fuel tank

Additional accessories available - Consult Lister-Petter

Product Support

- Recommended spares kits
- Special service tools
- Workshop Manual
- Master parts manual

General Data

		LPW2	LPW3	LPW4
Bore:	mm	86.0	86.0	86.0
	inch	3.38	3.38	3.38
Stroke	mm	80.0	80.0	80.0
	inch	3.15	3.15	3.15
Cylinder Capacity:	liter	0.93	1.39	1.86
	in ³	56.7	85.1	113.5
Lubricating Oil Capacity: (including filter)	liter	3.2	4.4	5.5
	US quarts	3.4	4.6	5.8
Fuel Consumption @1800 r/min: (75% Load)	l/h	1.9	2.6	3.4
	US gal/hr	0.5	0.7	0.9
Specific Fuel Consumption: (full load @ max. torque speed - 5% tol.)	g/kW h	230	230	230
	lb/hp h	0.38	0.38	0.38
Angles of inclination: (any direction)	Permanent	20°	20°	20°
	Temporary	25°	30°	30°
Minimum Idling Speed:	r/min	850	850	850
Combustion Air Required @2000 r/min.	l/s	13.2	19.8	26.3
	ft ³ /min	27.9	41.9	55.8
Dry Weight (including flywheel)	kg	112	150	180
	lb	247	330	396

Electrical System

		LPW2	LPW3	LPW4
Alternator Output:	amp	45	45	45
Starter Motor Power:	kW	1.4	1.4	2.0
Starter Motor Battery Cold Cranking Performance Rating: (BS3911-Part 2)	amp @ -8°C (18°F)	210	345	380
	amp @ -18°C (0°F)	350	600	670
Minimum Starting Temperature*: (without additional aids)	°C	-15°	-15°	-15°
	°F	5°	5°	5°

*Consult Lister-Petter Inc. concerning performance at lower temperatures.

LPW2 / LPW3 / LPW4

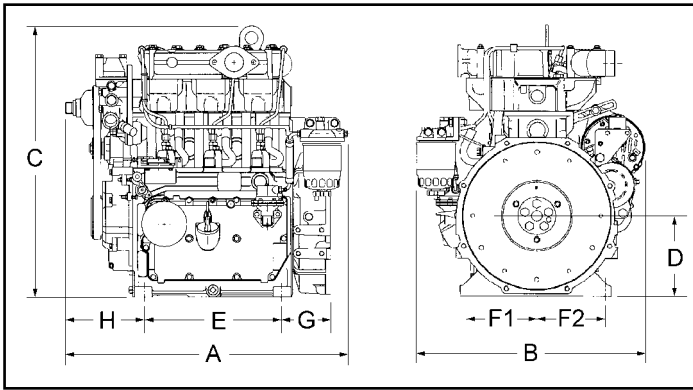

Principal Dimensions

	LPW2		LPW3		LPW4	
	mm	inch	mm	inch	mm	inch
A	496	19.5	596	23.5	696	27.4
B	493	19.4	493	19.4	493	19.4
C	574	22.6	574	22.6	574	22.6
D	170	6.7	170	6.7	170	6.7
E	184	7.2	284	11.2	384	15.1
F1	147	5.8	147	5.8	147	5.8
F2	142	5.6	142	5.6	142	5.6
G	108	4.3	108	4.3	108	4.3
H	170	6.7	170	6.7	170	6.7

Power Output

Engine Speed r/min	Continuous Power			Intermittent Power			Automotive Power			
	BS5514/ISO3046/DIN6271						DIN70020			
	LPW2	LPW3	LPW4	LPW2	LPW3	LPW4	LPW2	LPW3	LPW4	
3600	kW	Consult Lister- Petter						NA		
	hp									
3000	kW	13.4	20.1	26.8	14.7	22.1	29.5	14.5	21.4	28.9
	hp	18.0	26.9	35.9	19.8	29.6	39.5	19.4	28.7	38.8
2500	kW	11.8	17.7	23.6	13.0	19.5	26.0	13.0	19.3	26.0
	hp	15.8	23.7	31.6	17.4	26.0	34.7	17.4	25.9	34.9
2000	kW	9.7	14.5	19.3	10.6	15.9	21.2	10.6	15.9	21.4
	hp	13.0	19.4	25.9	14.3	21.3	28.5	14.2	21.3	28.7
1800	kW	8.5	12.8	17.2	9.3	14.0	18.9	9.4	14.2	18.9
	hp	11.4	17.2	23.0	12.5	18.9	25.3	12.6	19.0	25.3
1500	kW	6.8	10.3	13.6	7.5	11.3	15.0	7.6	11.3	15.2
	hp	9.1	13.8	18.2	10.0	15.2	20.0	10.2	15.2	20.4
1800 Gen Set	kW	9.3	13.9	18.6	10.2	15.3	20.5			
	hp	12.5	18.6	24.9	13.7	20.5	27.5			
1500 Gen Set	kW	7.5	11.3	15.0	8.2	12.4	16.5			
	hp	10.1	15.2	20.1	11.0	16.6	22.1			

Torque - Variable Speed

Engine Speed r/min	Automotive Power			
	DIN70020			
	LPW2	LPW3	LPW4	
3000	Nm	46.2	68.1	92.0
	Ft Lbs	34.1	50.2	67.9
2500	Nm	49.6	73.7	99.3
	Ft Lbs	36.6	54.4	73.2
2000	Nm	50.6	75.9	102.2
	Ft Lbs	37.3	56.0	75.4
1800	Nm	49.9	75.3	100.3
	Ft Lbs	36.8	55.5	74.0
1500	Nm	48.4	71.9	96.8
	Ft Lbs	35.7	53.0	71.4

For further information, contact:

Construction:

Ribbed, thin-wall cast iron crankcase for quiet operation. Crankcase includes a service door for easy access. Internal crankcase breather for reduced emissions. Extra large bearing surfaces for low bearing loads and long life.

Rotation:

Counter-clockwise, looking at the flywheel end.

Cooling:

Water circulation pump with thermostat is driven by a polyvee long-life belt. Engine includes an integrated bypass system and is designed for ambients up to 52°C (125°F).

Lubrication:

Designed to run at high angles of inclination and includes a full flow spin-on cartridge filter. Service free hydraulic tappets. Lubricating oil pump is a gear-driven, positive displacement design. Oil service interval is 250 hours.

Fuel & Combustion Systems:

Direct injection combustion system for easy starting and low fuel consumption. Cylinder head is a cross-flow, high swirl design to increase efficiency of combustion. Self-vent fuel system eliminates the need for bleeding. Individual fuel pumps per cylinder increases reliability and lowers service costs.

Starting:

Standard equipment includes an inlet manifold heater plug to ensure quick starting.

Governing:

Mechanical governing is provided for either variable or constant speeds depending on build. Generator set governing is available for 1500, 1800, 3000 & 3600 r/min.

Drives:

Full power is available at the flywheel end for axial or radial drives. Limited power drives are available for mounting at the gear end.

Mounting:

Hold-down feet are integral with the crankcase for base mounting.



© Copyright Lister-Petter, Inc.
June, 2001
555-00444
Printed in the USA

The information in this data sheet is of a general nature and does not form part of any contract or warranty. We have made efforts to ensure that the information is accurate but reserve the right to amend specification and information without notice or any obligation or liability. The set illustrated is not necessarily the standard build.