

Starlite Series Industrial Engines



SA432i1

Variable speeds
Rated point 2600 r/min

45 kWm | 60.3 bhp

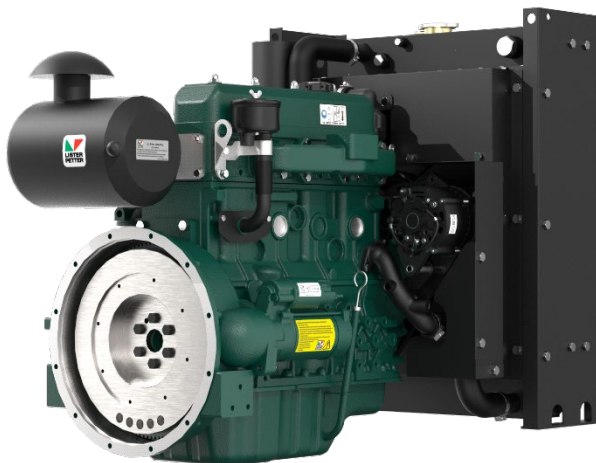

OVER VIEW

The engine is specifically designed as an industrial engine suitable for use in stage II emissions territories. It is durable, reliable and easy to maintain. It is designed for continuous operation in ambient temperatures up to 52° C (125° F) and a cold start capability down to -25° C (-13° F).

G Build

Note:

For further information and approval please contact Applications Department

* Optional items standard on most builds.

BASIC ENGINE CHARACTERISTICS

- direct fuel injection
- 4 cylinders
- liquid cooled
- natural aspirated

DESIGN FEATURES AND EQUIPMENT

- electric starting
- anti clockwise rotation, looking on the flywheel end
- SAE Flywheel connection
- SAE compliant flywheel housing
- radiator and fanguard
- cast-iron structural crankcase
- self-vent fuel injection system
- mechanical fuel injection equipment
- mechanical and electronic governing variants
- flywheel and gear ring
- cyclonic heavy duty airfiltration
- oil pressure protection switch
- coolant temperature protection switch
- spin-on full flow lubricating oil filter
- fuel filter
- intake and exhaust manifolds
- operators' handbook

OPTIONAL ITEMS

A range of options are available that allows you to select a specification that matches your requirements; please consult your Lister Petter Engine distributor.

TECHNICAL DATA

Engine Model	SA432i1	
Type of fuel injection	Direct	
Number of cylinders	4	
Aspiration	Natural	
Direction of rotation (flywheel end)	Anti clockwise	
Nominal cylinder bore	mm	98
	in	3.86
Stroke	mm	105
	in	4.13
Total cylinder capacity	litre	3.17
	in ³	193.4
Compression ratio	18.5:1	
Firing order (number 1 cylinder is at the gear end)	1-3-4-2	
Alternator	14V × 35A	
Starter motor	12V × 3.8kW	
Fuel injection pump	Mechanical	
Speed governor	Electronic	
Speed regulation class	ISO 8528 G3	
Fly wheel housing	SAE 4	
Fly wheel	SAE J620 Size 7.5"	
Heat rejection (kw)	35	

EXHAUST AND INTAKE SYSTEM

Parameter	Engine Model
	SA432i1
EXHAUST	
Maximum allowable back-pressure (kPa)	≤ 10
Exhaust gas flow, (m ³ /min)	5.7
Emissions level	Stage II
Exhaust gas temperature, continuous (°C)	336
Exhaust gas temperature, overload (°C)	375
Exhaust pipe diameter -recommended	63.5mm
INTAKE	
Maximum allowable inlet restriction (kPa)	≤ 4
Air intake flow (m ³ /h)	233.4

ENGINE COOLANT SYSTEM

Parameter	Engine Model
	SA432i1
Cooling method	Liquid cooled (belt driven water pump)
RADIATOR	
Material	Aluminium
Radiator face area (m ²)	12.6
Pressure cap setting (kPa)	90
FAN	
Diameter (mm)	450
Number of blades	7
Material	Plastic
Type	Pusher
COOLANT	
Cooling package maximum operating temperature (°C)	≤110
Total system with radiator capacity (L)	11.4
Total system without radiator capacity (L)	4.8
Thermostat type	Wax Capsule
Thermostat opens at... (°C)	72
Thermostat fully open at... (°C)	82
Minimum temperature to engine (°C)	-25
Maximum static pressure head at pump (meters at 1500rpm)	14
Cooling fan flow rate (m ³ /s)	1.27

Recommended coolant:

50% ethylene glycol with a corrosion inhibitor (BS 6580 : 1992 or ASTM D3306-89 or AS2108) and 50% de-ionised water

ENGINE LUBRICATION SYSTEM

Parameter	Engine Model
	SA432i1
Lubricating method	Pressure feed and splash
Sump capacity including filter (L)	8.0
Service Interval (hr)	250
Oil filter type	Spin-on full flow oil filter
Oil Specification	API CH-4
	ACEA E5
Oil consumption % SFC	≤ 0.1%
Oil consumption, 100% (l/hr)	0.016
Lubricating oil temperature (°C)	90-105
Maximum oil temperature (°C)	108
Maximum operation angle of engine (degrees)	10°

SA432i1 PERFORMANCE DATA			
Speed (rpm)	Engine power (kW)	Torque (N·m)	Fuel consumption (g/kwh)
2600	45.0	165.2	228
2500	45.0	172.0	229
2400	44.2	176.0	226
2300	42.9	178.0	224
2200	41.2	179.0	221
2100	39.6	180.0	220
2000	37.7	180.0	218
1900	36.0	181.0	219
1800	36.0	191.0	217
1700	34.7	195.0	219
1600	32.5	194.0	215
1500	29.5	188.0	217
1400	26.4	180.0	216
1300	22.6	166.0	216
1200	19.6	156.0	219
1100	16.9	147.0	221
1000	13.9	133.0	223

SA432i1 PERFORMANCE CURVE

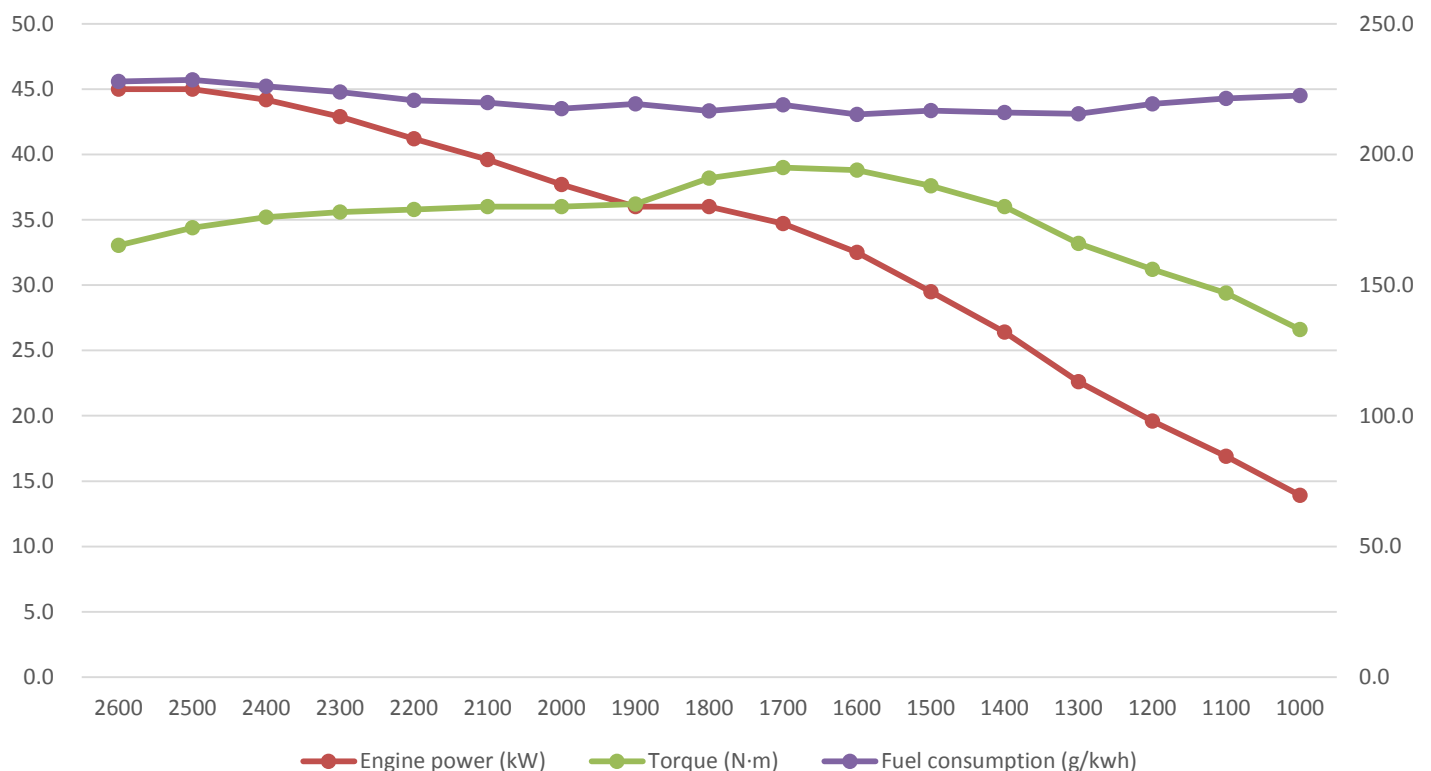

ENGINE NOISE LEVELS

Parameter	Engine Model
	SA432i1
Sound pressure level at 1m	≤98 dB(A)

APPROXIMATE DIMENSIONS AND WEIGHT

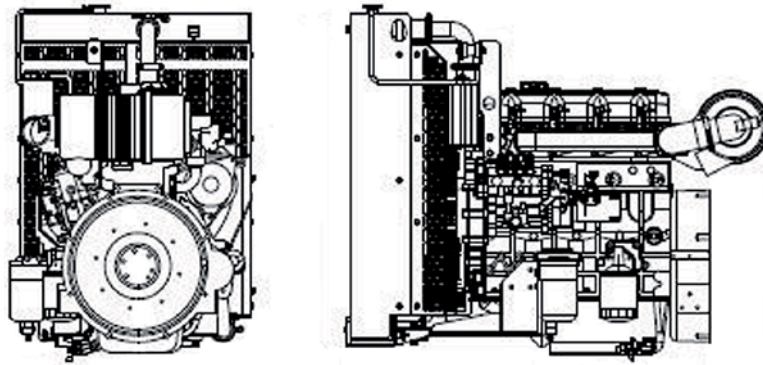

Engine model		SA432i1
Dry weight	kg	302
	lb	664
Length (A)	mm	1155
	in	45
Width (B)	mm	670
	in	26.1
Height (C)	mm	845
	in	33.0

TYPICAL PACKING CASE DIMENSIONS

Engine packing case dimensions	Radiator packing case dimensions	Container quantities (Engine with Radiator)		
		20FT	40FT	40HQ
L*W*H(mm)	W*D*H(mm)			
975*645*870	790*430*1100	26 sets	50 sets	62 sets



Head Office
Lister Petter Engine Company Limited

Rutland House, Minerva Business Park,
Lynch Wood, Peterborough, PE2 6PZ.

Distributor Address

LISTER PETTER DIESEL S.A.S.
Pq. Industrial Los Pinos Bg 10
Manizales - Caldas - Colombia
Tels: 606 8982377
Cel: 310-3048367
ventas@listerpetter.com.co



enquiry@listerpetter.com
www.listerpetter.com